

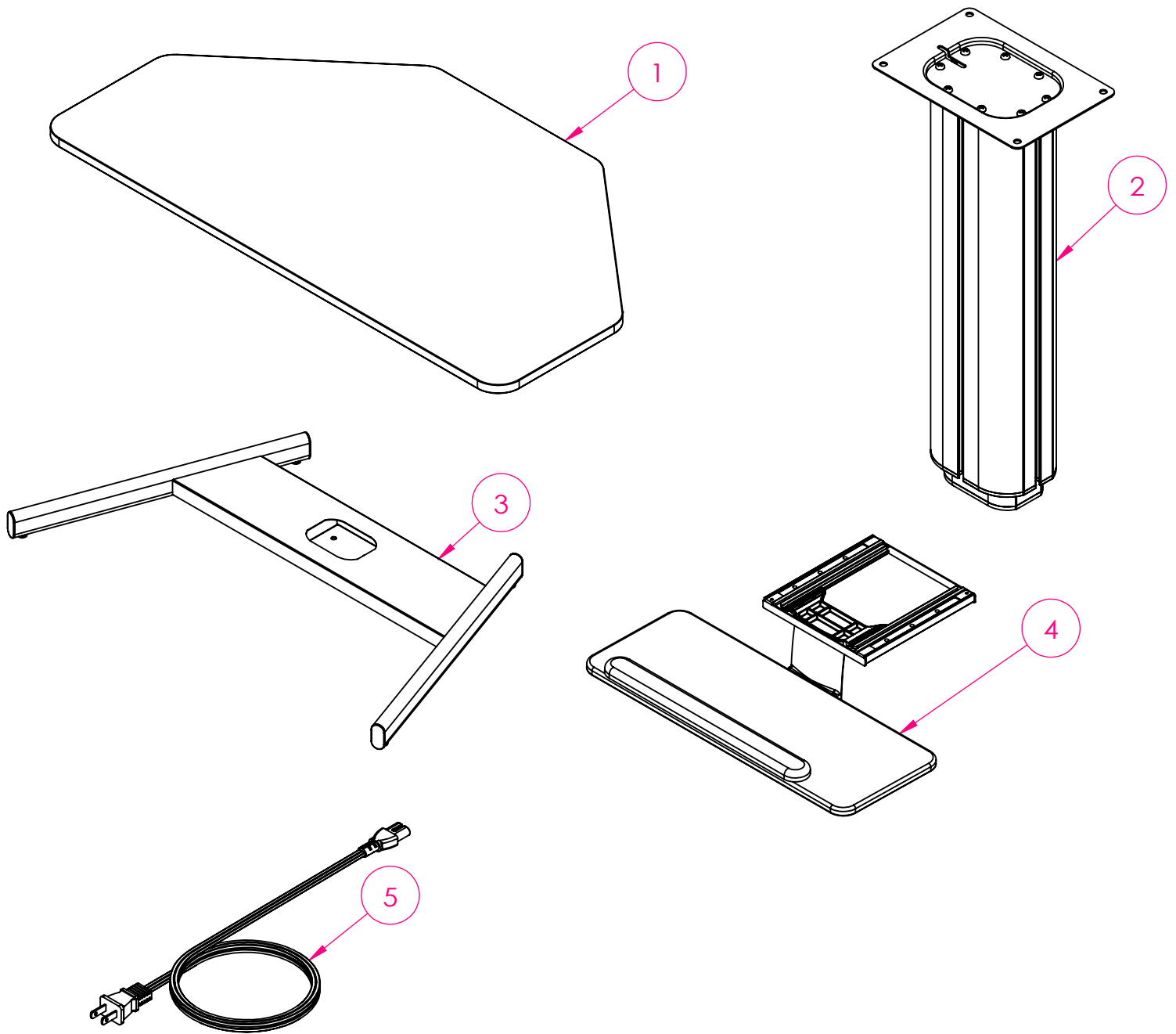

Made in Taiwan

HC104
組裝說明書
Installation Instruction

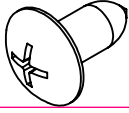
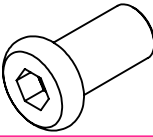
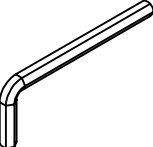

零組件編號 Part NO.	零組件名稱 Part Name	零組件數量 Part Qty
1	桌板 Desk	1
2	立柱 Column	1
3	底座 Base	1
4	鍵盤托盤 Keyboard Tray	1
5	電源線 Power Cable	1

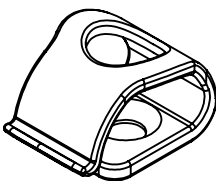
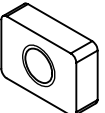
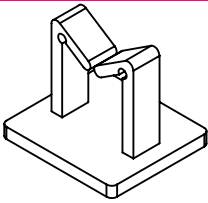
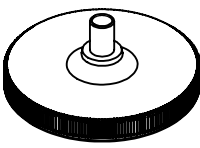
五金包編號 Part No.	單件編號 Sub-part No.	單件數量 Sub-part Qty.	規格 Description	圖示 Image
A	A-1	6	1/4"*19mm 十字半圓頭尖尾木螺絲 1/4"*19mm Wood Screw	
B	B-1	8	M8*15mm內六角平頭螺絲 M8*15MM Hex Socket Flat Head Cap Screw	
	B-2	1	5mm 六角扳手 5mm Allen Wrench	
C	C-1	2	M5*10mm 皿頭螺絲 M5*10mm Philips Screw	
	C-2	2	半圓形線扣 Cable Clip	
	C-3	2	M5板型螺母 M5 Square Nut	
D	D-1	4	自黏線扣 Adhesive Cable Clip	
E	E-1	4	調整腳墊 Adjustable Feet	

※需自備十字螺絲起子

※ADDITIONAL TOOLS REQUIRED

Phillips Screwdriver

步驟一：使用十字螺絲起子將(A-1)螺絲穿過④鍵盤托盤後鎖入①桌板。
Step1 : Use (A-1) wood screw to screw ④ <Keyboard> into the back of ① <Desk>.

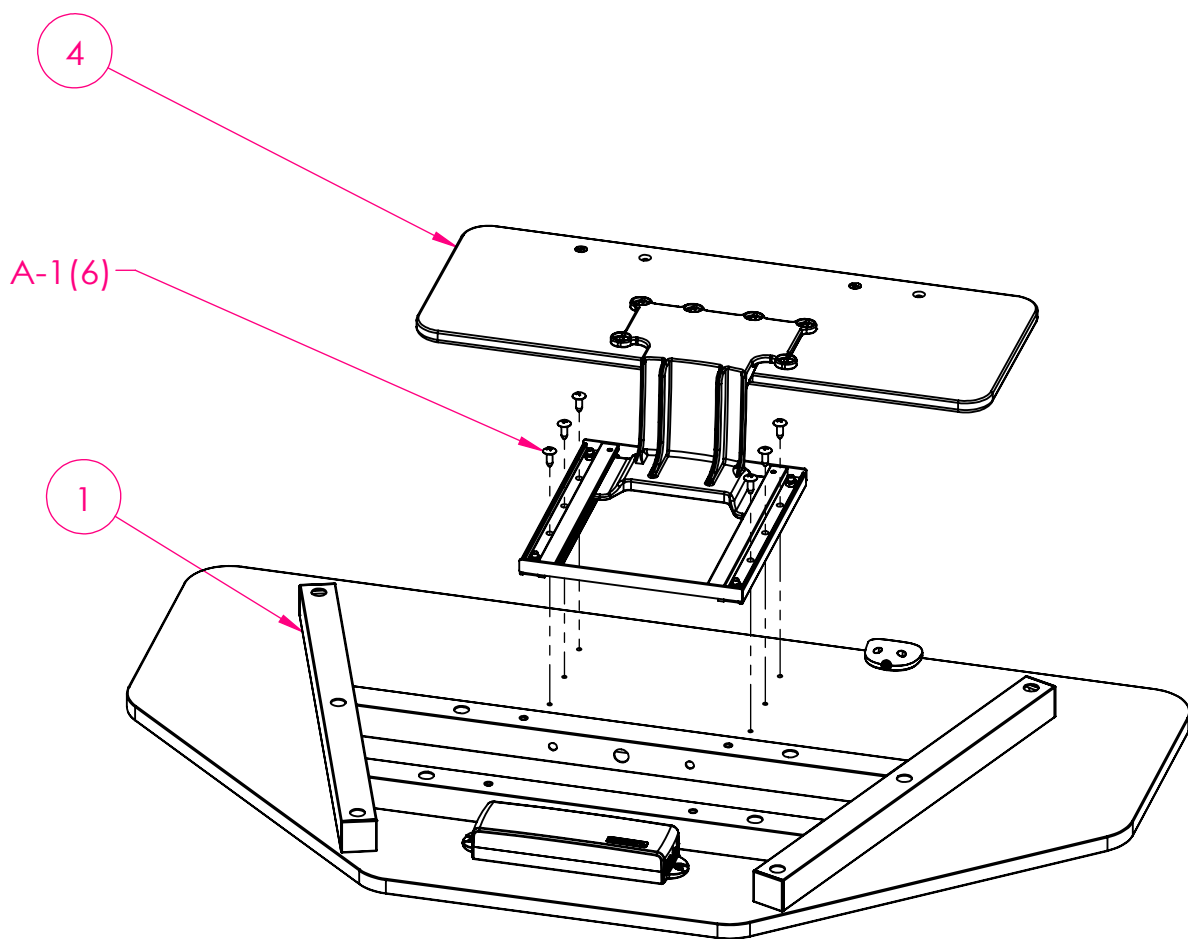

步驟二：用(B-2)六角扳手與(B-1)螺絲把①桌板與②立柱鎖在一起固定。

Step 2 : Use (B-2) Allen wrench and (B-1) screw to fix ① <Desk> and ② <column> together.

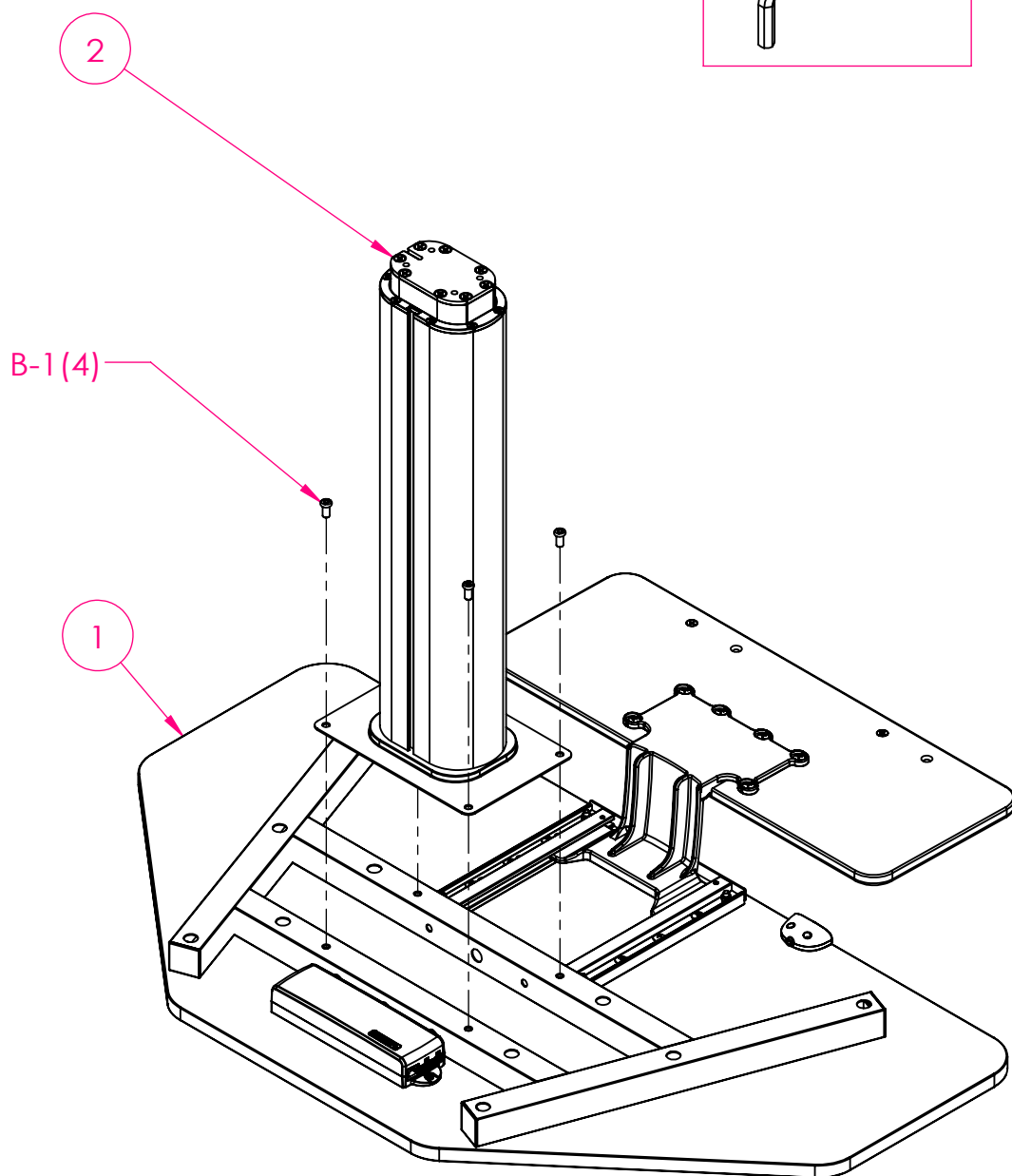

步驟三：將(C-1)螺絲穿過(C-2)後鎖入(C-3)，接著將其卡入立柱側面的滑槽，調整到所需高度後用十字螺絲起子鎖緊固定。

Step3 : Thread the (C-1) screw through (C-2), then lock it into (C-3).

Next, insert it into the groove on the side of the ②<column>,

adjust it to the desired height, and use a Phillips screwdriver to lock it in place.

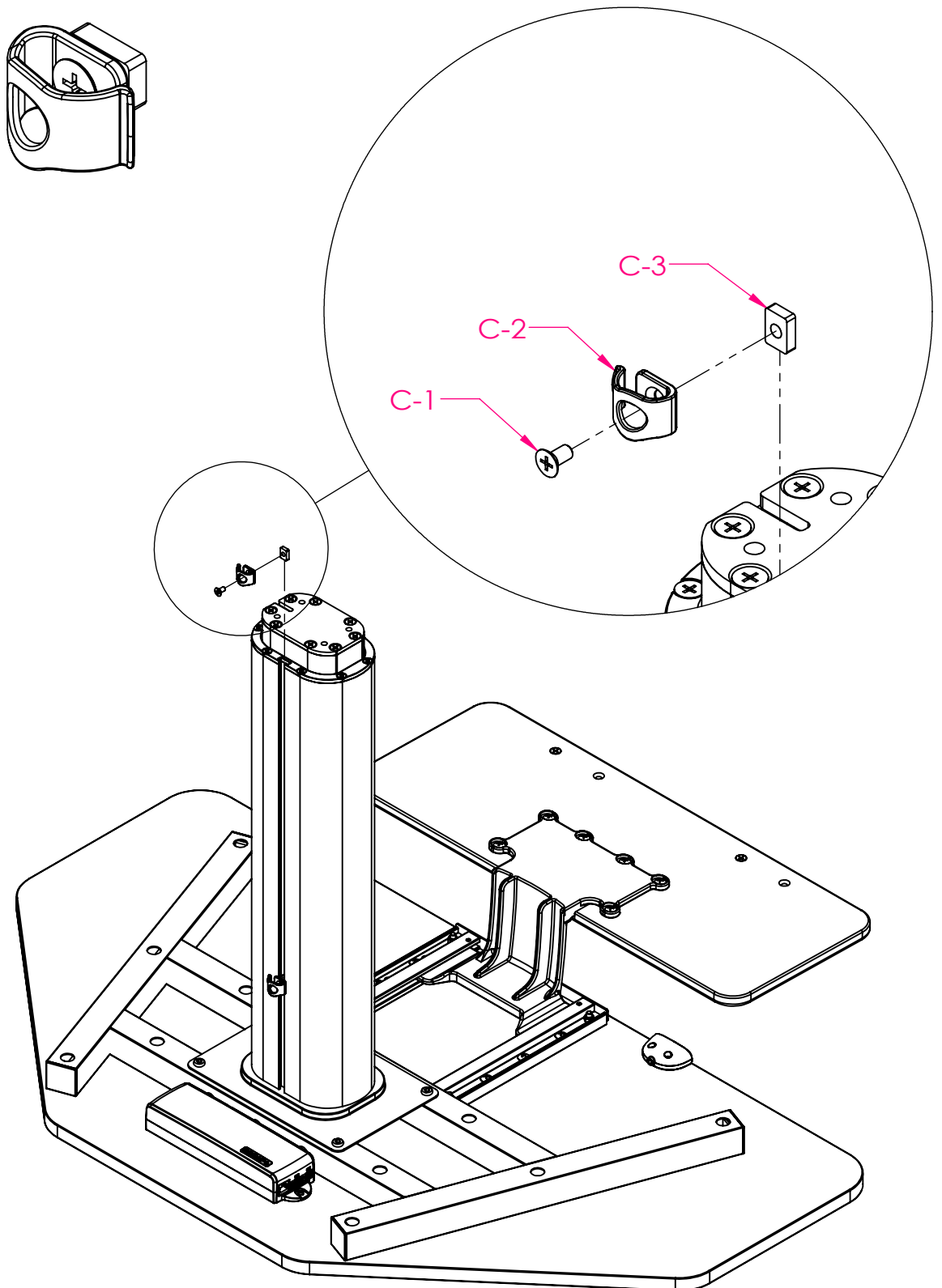

步驟四：用(B-2)六角扳手與(B-1)螺絲把③底座與②立柱鎖在一起固定
Step 4 : Use (B-2) Allen wrench and (B-1) screw to fix ③<Base>
and ②<column> together.

使用B-2
USE B-2 TOOL

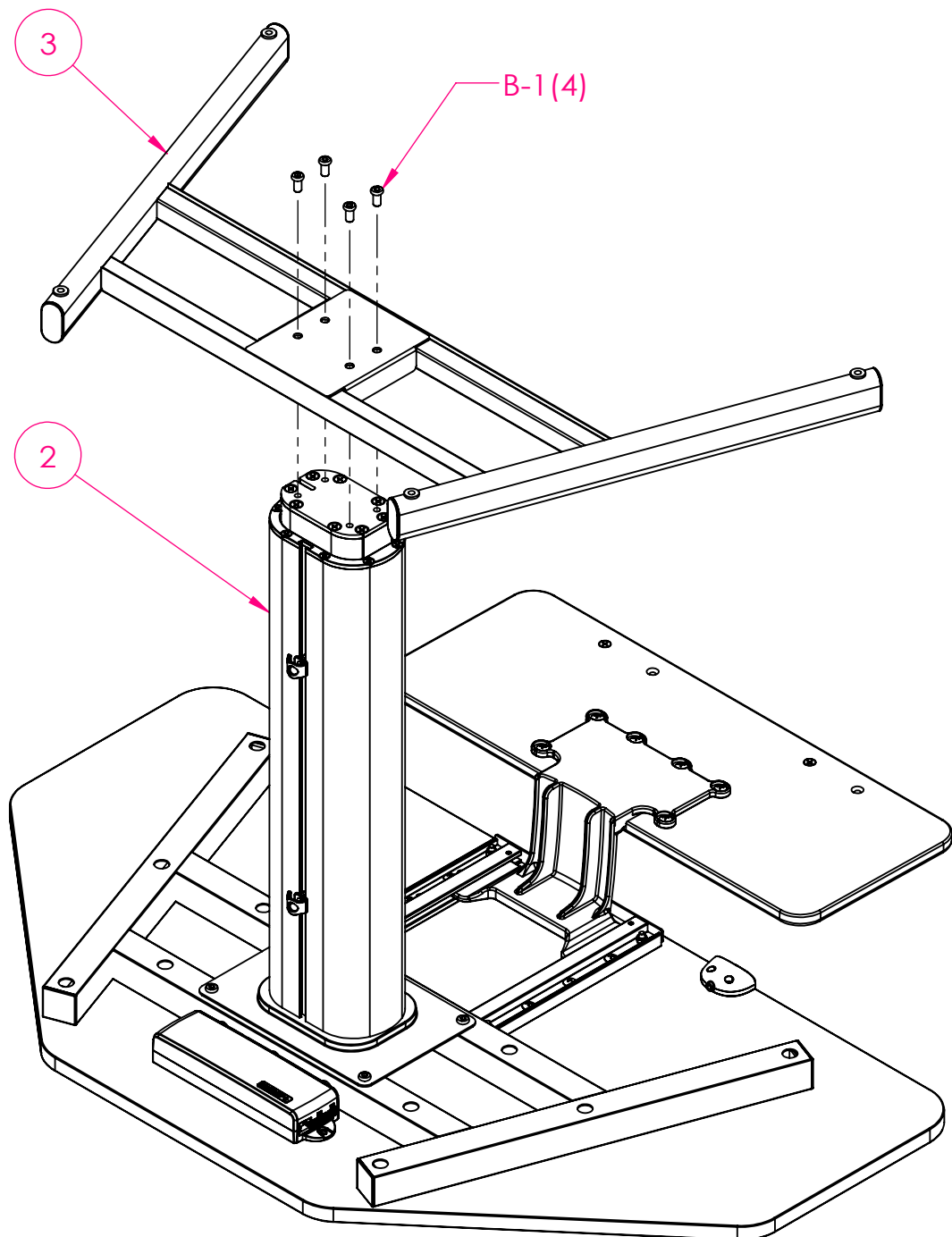
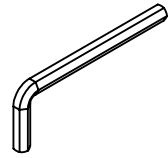

步驟五：把(G-1)調整腳墊鎖在③底座上。
Step 5 : Locking (G-1) Adjustable Feet with the ③<base>.

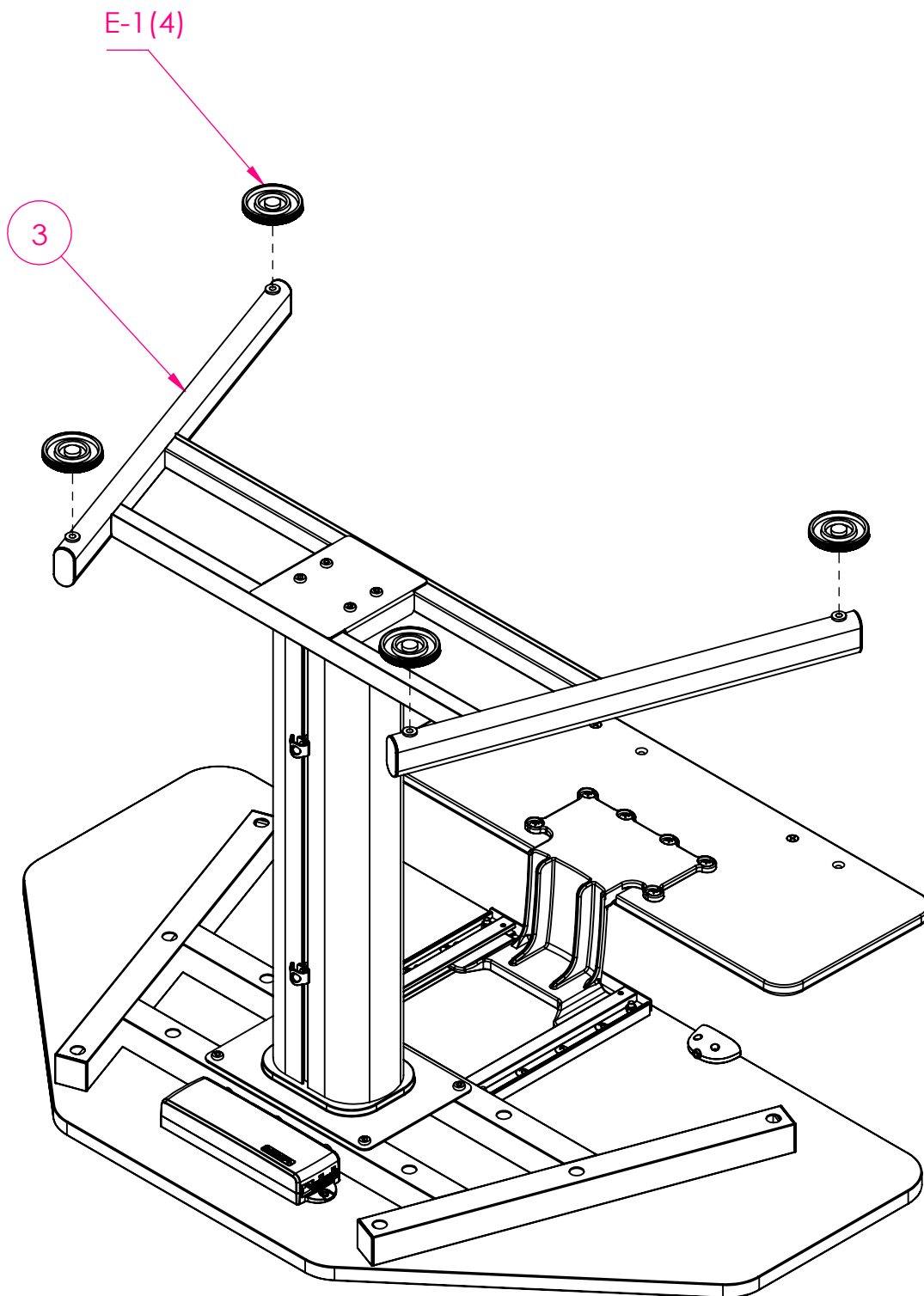

步驟六：將②立柱的连接線、⑥控制器的连接線以及⑦電源線如圖接上⑤控制盒。
再用D-1線扣將線材固定於桌面下方。

(圖面位置為參考位置，可黏貼在顧客認為合適的位置。)

Step 6 : Connect the ②Column cable, ⑦ Control cable and ⑧ Power cable to ⑥Control box as shown in the diagram.
Then use <D-1> Adhesive Cable Clip to fix the cables under the desk.
(The example picture is a reference position ,
it can paste at a location deemed suitable by the customer.)

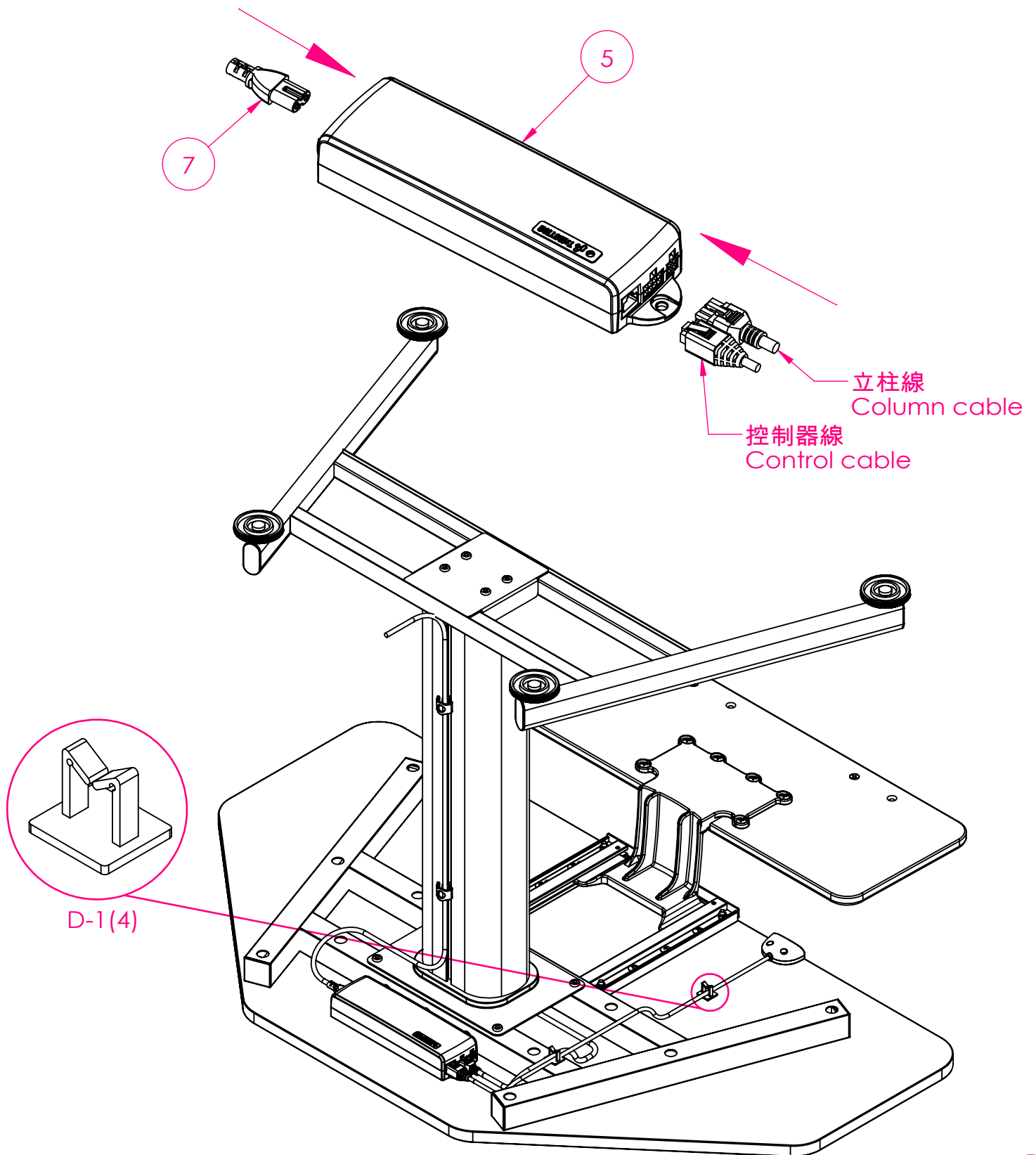

步驟七：把桌子立起，完成組裝。

Step 7: Stand up the table, complete the assembly.

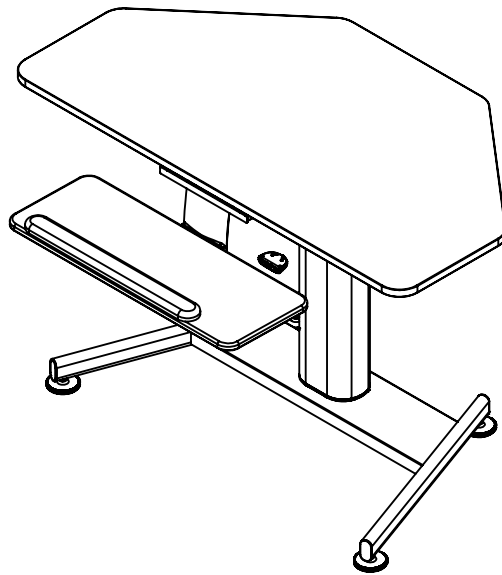

完成組立並接通電源後要先進行"歸零"，來重置立柱。

- 同時按住上升與下降按鈕不放，立柱將會開始下降。
 - 當立柱下降到最低並發出"嗶"聲後，代表完成歸零。
若是沒有發出"嗶"聲，請於立柱位於最低點三秒後放開按鈕。
- ※ After completing the assembly, firstly you must process "zero set" the column once.
- Press and hold the UP ▲ and DOWN ▼ buttons at the same time.
Continue to hold the buttons.
The column will lower until reach the bottom point.
 - Release the buttons once the system beeps. If it does not beep,
continue to hold the buttons for 3 seconds after the column reach the lowest point .
 - The system is now "zero set".

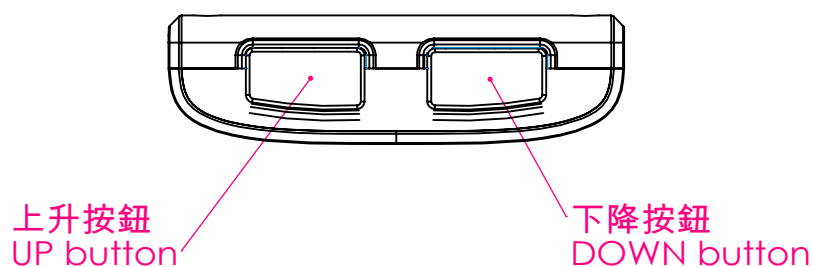

使用方式：

長按上升或者下降鈕即可使立柱運作，當桌面到達使用者所要的高度時放開按鈕即可停止。

GENERAL OPERATION：

Move the column up or down by pressing UP ▲ or DOWN ▼ button until the column reaches the desired height.
The column will continue to move up or down until you release the button or until the maximum or minimum height is reached.

程鼎實業股份有限公司

台灣台中市大雅區神林路一段526號

Tel:886-4-25679181 Fax:886-4-25669582

統一編號：80112978

Website: www.cdgreat-officefurniture.com

C.D. Great Furniture Co., Ltd.

No.526, Sec. 1, Shenlin Rd., Daya Dist., Taichung City 428, Taiwan.

Tel:886-4-25679181 Fax:886-4-25669582

Website : www.cdgreat-officefurniture.com